



Green Synthesis of Zinc Sulfide Nanoparticles using *Jatropha curcas* Linn. for Photocatalytic Degradation of Methylene Blue

BEVERLY ANN N. BANIAGA¹ and DANILET VI M. MENDOZA^{2*}

¹Ebar Abstracting Company Inc. 4F Philcox Building, Legazpi Village, Makati City, Philippines.

²Natural and Applied Sciences Department, College of Arts and Sciences Nueva Ecija University of Science and Technology General tiño St., Cabanatuan City 3100, Philippines.

*Corresponding author E-mail: niletmendoza@yahoo.com

<http://dx.doi.org/10.13005/ojc/380219>

(Received: December 23, 2021; Accepted: April 13, 2022)

ABSTRACT

Green synthesis of materials such as nanoparticles pose several advantages including greener and lesser volume of waste generation making it a less hazardous and eco-friendly alternative. Nanoparticles have been used widely for treatment of wastewater. In the study, synthesis of zinc sulfide (ZnS) nanoparticles were conducted through green synthesis using *Jatropha curcas* Linn latex and its photocatalytic activity in degrading methylene blue was determined. Synthesized zinc sulfide nanoparticles were characterized based on its absorbance and average size determined through microscopic analysis. Absorbance analysis showed that there is dependency on the concentration of nanoparticles and latex formulations used. The average size of the synthesized nanoparticles is 80 nm. By monitoring changes in absorbance for 90 min, the photocatalytic degradation was determined. Photocatalytic degradation activity of 7.72% was recorded during the first 15 min which was the highest reading obtained. These findings suggest that nanoparticles synthesized thru green synthesis may be developed as an eco-friendly and non-hazardous materials for wastewater treatment.

Keywords: ZnS nanoparticle, *Jatropha curcas* Linn., Wastewater treatment, Methylene blue, Green synthesis, Photocatalysis.

INTRODUCTION

Green synthesis of materials have gaining interest worldwide. This approach offers the advantages of producing eco-friendly and nonhazardous materials such as nanoparticles¹. It has been utilized lately by researches to produce nano and micro sized materials that can aid in

bioremediation^{2,3}. One of the main focuses of studies regarding bioremediation is the development of wastewater treatment methods that utilizes the green chemistry approach without sacrificing the efficiency of the product. Photocatalytic degradation offers a pathway of degrading organic pollutants that is consistent with this goal. This technique is one of the promising technologies for wastewater treatment.



Organic dyes such as methylene blue is considered as one of the most useful organic dyes that has been consistent component of wastewaters of textile, paper, printing and other industries. Persistence of methylene blue in water systems pose serious environmental challenges. Thus, its removal in water systems has attracted attention worldwide.

Nanocomposites such as graphene oxide-nickel sulfide⁴, graphene oxide-nickel oxide⁵ and nanoparticles such as titanium oxide^{6,7}, cadmium sulfide⁸, ferric oxide⁹, silver¹⁰, zinc oxide¹¹ and zinc sulfide¹² have found its use on photodegradation of organic dyes and other environmental pollutants. Zinc sulfide (ZnS) nanoparticles may be produced by using latex of different plants as reducing agent.

In the study, ZnS nanoparticles were synthesized. The effect of using different concentrations of the latex on the concentration of the product was analyzed. The photocatalytic degradation studies of the synthesized product was also evaluated using methylene blue as the representative organic dye.

Methodology

Synthesis of ZnS nanoparticles

ZnS nanoparticles were synthesized based on the previously published method with some modifications. Crude *Jatropha curcas* Linn. latex. The latex was collected by cutting the green stems of the plant. About 0.15%, 0.10% and 0.05% (v/v) latex solutions were prepared using 1 mL of crude latex using triple distilled water as solvent. Afterwards, 20 mL of latex solution was mixed with 2.5 mM of aqueous zinc acetate solution. The mixture was mixed vigorously using a magnetic stirrer for 24 h at room temperature. To remove unreacted reagents, the mixture was subjected to centrifugation at 15000 rpm for 15 min and re-dispersed in distilled deionized water.

Characterization of ZnS nanoparticles

To qualitatively determine the presence of ZnS nanoparticles, 6 mL of the mixture was placed each on 10-mL test tubes. To each tube, 2 mL solution of sodium hydroxide, ammonium hydroxide, potassium ferricyanide (III) and lead acetate were added. The tubes were evaluated based on the presence of precipitate.

The mixtures were subjected to AFM analysis to confirm its average size in nanometer range and UV-Vis analysis to determine its concentration. The product with the highest concentration was used in the photocatalytic degradation studies.

Photocatalytic degradation of methylene blue

The synthesized product was placed in a black box with a 500-watt halogen lamp which was used as the visible light source (Fig. 1). Samples were collected every 15 min for 90 min and was subjected for spectral analysis. Based on the absorbance reading, the degradation efficiency was calculated for each sample. A water pump was used to control the temperature of the system.

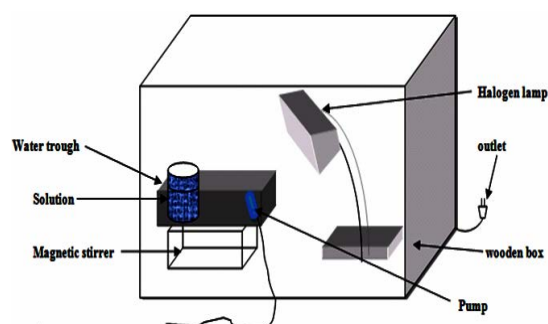

Fig. 1. Photocatalytic degradation set-up

RESULTS

Table 1: Qualitative Test for the presence of Zn²⁺ and S²⁻ in the synthesized product

Reagents added	Precipitate formed
Sodium hydroxide	White; Zn(OH) ₂
Ammonium hydroxide	White; Zn(OH) ₂
Potassium ferricyanide(III)	Yellow orange; zinc ferricyanide(III)
Lead acetate	Black; PbS

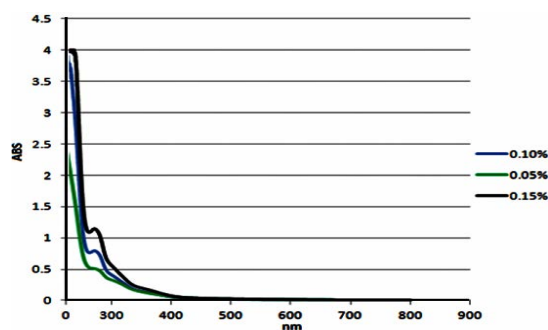

Fig. 2. UV-Visible absorption spectra of synthesized ZnS in different latex formulations; (0.1%- blue, 0.05%- green and 0.15%- black)

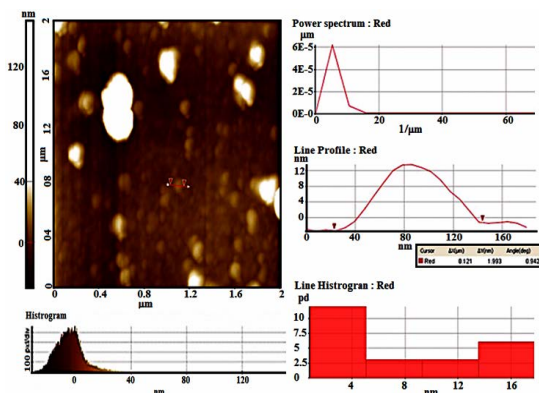

Fig. 3. Atomic Force Microscopy line profile of ZnS nanoparticle showing an average size of 80nm

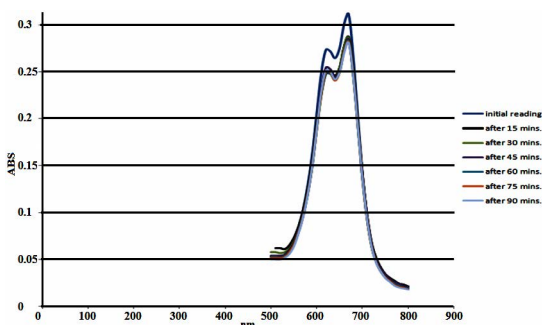

Fig. 4. The different absorbance peak of Methylene blue every 15 min interval of sample collection

Table 2: Degradation efficiency calculated for 90 min at 15 min interval

Time Elapsed (minutes)	Degradation Efficiency (%)
15	7.72
30	0.35
45	0.70
60	0.35
75	0.35
90	0.35

DISCUSSION

Synthesis of ZnS nanoparticles

ZnS nanoparticles were synthesized through green chemistry approach using *Jatropha curcas* Linn. latex as reducing agent. A yellowish brown solution was obtained for all treatments signifying the distinctive color of ZnS. The solutions obtained were subjected to characterization studies to confirm its identity and average size.

Characterization of synthesized ZnS nanoparticles

The synthesized ZnS nanoparticles were confirmed using qualitative tests for the presence

of Zn^{+2} and S^{-2} ions. Table 1 summarizes the observations based on precipitate formation. White precipitate was observed after addition of sodium hydroxide and ammonium hydroxide solution. This confirmed the presence of Zn^{+2} in the product which caused the formation of $Zn(OH)_2$ precipitate. In the reaction of potassium ferricyanide (III) and ZnS, the precipitate observed was yellow orange, the distinct color of zinc ferricyanide (III). On the other hand, the qualitative test for S^{-2} ions in the reaction of lead acetate and ZnS, formation of black PbS was observed.

UV-Visible spectroscopy was also utilized to confirm the identity of the product as well as to determine its concentration. As shown in Fig. 2, all products obtained by using varied latex concentrations have the same maximum absorption peaks at 272 nm corresponding to the distinct absorbance of ZnS nanoparticles¹³. Moreover, as depicted in the spectra, the absorbance is dependent on the latex concentration used. Increasing the latex concentration used caused an increase in the concentration of the product formed since absorbance is directly proportional to concentration. The concentrations of the products formed were $8.48 \times 10^{-5}M$, $1.89 \times 10^{-4}M$ and $2.87 \times 10^{-4}M$ for 0.05%, 0.10% and 0.15% (v/v) of latex used respectively.

The products obtained were polydispersed and having an average size of 80 nm based on the Atomic force micrograph (Fig. 3). This confirmed that the product synthesized was indeed in the nanometer range. Moreover, it was observed that the size of the product is not dependent on the concentration of the latex used to synthesize it. This observation may be explained by the function of the latex in this green synthesis approach. The latex is primarily the source of S^{-2} ions due to its components curcacycline and curcain. These components also act as a reducing and stabilizing agent in zinc acetate which is the Zn^{+2} donor¹⁴. Since these components were enzymes, their stabilizing capability was dictated by their activity on the stock solution and not on the different concentrations used.

Photocatalytic activity of synthesized ZnS nanoparticles

Photocatalytic degradation was conducted by subjecting ZnS nanoparticles with MB in the presence of light. The absorbance peak of the MB

at 664 nm was monitored. Fig. 4 showed that the highest photodegradation of MB was achieved during the first 15 minutes. The absorbance during the first 15 min dropped tremendously.

To further illustrate the photocatalytic activity of the product, %degradation efficiency was calculated based on the previous studies¹⁵. The maximum efficiency obtained was 7.72% that occurred during the first 15 min (Table 2). The decrease in absorbance was minimal for the succeeding minutes as depicted by the almost constant %degradation efficiency calculated.

CONCLUSION

Synthesis of zinc sulfide nanoparticles were facilitated by the use of latex of *Jatropha curcas Linn* as the reducing agent. Qualitative tests for Zn⁺² and S⁻² confirms its presence. Absorbance peak at 270.20 nm further confirmed the synthesized ZnS nanoparticle size. AFM analysis showed that the products obtained were polydispersed having an average size of 80 nm. The concentration

of ZnS nanoparticles were dependent on the concentration of the latex used. The size of the nanoparticle is also determined to be independent on the formulation of latex. Maximum degradation of MB was achieved during the first 15 min with a % degradation efficiency of 7.72. The results suggest that zinc sulfide nanoparticles can be synthesized through green chemistry approach with possible relevant degradation efficiency for organic dyes such as methylene blue. Optimum conditions for its photocatalytic degradation as to pH and temperature against methylene blue and other organic dyes may be determined.

ACKNOWLEDGMENT

The authors express their gratitude to the faculty, administration and staff of the Nueva Ecija University of Science and Technology for their support in the conduct and publication of the study.

Conflict of Interest

The authors declare that there is no conflict of interest regarding the publication of the study.

REFERENCES

- Martin K. D. G; Padilla K. G. V. *Orient. J. Chem.*, **2020**, *36*(3).
- Salam, H. A.; Rajiv, P.; Kamaraj, M.; Jagadeeswaran, P.; Gunalan, S.; & Sivaraj, R. *Int Res J Biol Sci*, **2012**, *1.5*, 85-90.
- Nand K.; Roy, J.M.; Ganesan, P.; Anusmita, D.; Sudeshna, G.; Elancheran, R.; Jibon, K.; Ajaikumar, B.K. *Current Nanomaterials.*, **2017**, *2*(1), 3-10.
- Manikandan, V.; Elancheran, R.; Revathi, P.; Suganya, P.; Krishnasamy, K. *Bull Mater Sci.*, **2020**, *43*, 265.
- Venkatachalam, M.; Ramakrishnan, E.; Palanisamy, R.; Umopathy, V.; Palani, S.; Kuppusamy, K. *Asian J. Chem.*, **2021**, *33*(2), 411-422.
- Lachheb, H.; Puzenat, E.; Houas, A.; Ksibi, M.; Elaloui, E.; Guillard, C.; Herrmann, J. M. *Appl. Catal. B.*, **2002**, 75-90.
- Houas, A.; Lachheb, H.; Ksibi, M.; Elaloui, E.; Guillard, C.; Herrmann, J. M. *Appl. Catal. B.*, **2001**, 145-157.
- Soltani, N.; Saion, E.; Yunus, W. M. M.; Erfani, M.; Navasery, M.; Bahmanrokh, G.; Rezaee, K. *Appl. Surf. Sci.*, **2014**, *290*, 440-447.
- Wang, K.; Yu, L.; Yin, S.; Li, H.; Li, H. *Pure Appl. Chem.*, **2009**, *81*(12), 2327-2335.
- Reyes D. F. *Orient. J. Chem.*, **2020**, *36*(4).
- Abdollahi, Y.; Abdullah, A. H.; Zainal, Z.; Yusof, N. A. *Int. J. Mol. Sci.*, **2012**, *13*(1), 302-315.
- Pouretedal, H. R.; Norozi, A.; Keshavarz, M. H.; Semnani, A. *J. Hazard. Mater.*, **2009**, *162*(2-3), 674-681.
- Nanda, J.; Sapra, S.; Sarma, D. D.; Chandrasekharan, N.; Hodes, G. *Chem. Mater.*, **2000**, *12*(4), 1018-1024.
- Bar, H.; Bhui, D. K.; Sahoo, G. P.; Sarkar, P.; De, S. P.; Misra, A. *Colloids Surf. A Physicochem. Eng.*, **2009**, *339*(1-3), 134-139.
- Chen, L.; Wang, C.; Li, Q.; Yang, S.; Hou, L.; Chen, S. *J. Mater. Sci.*, **2009**, *44*(13), 3413-3419.